

SUBMITTAL DATA SHEET



Series Name: Slim Duct Energy Star Series

Model Number: SZ24H525ZMO / D24H525ZMO

Slim Duct Heat Pump System

Location:	Approval:
Engineer:	Date:
Submitted to:	Construction:
Submitted by:	Unit #:
Reference:	Drawing #:

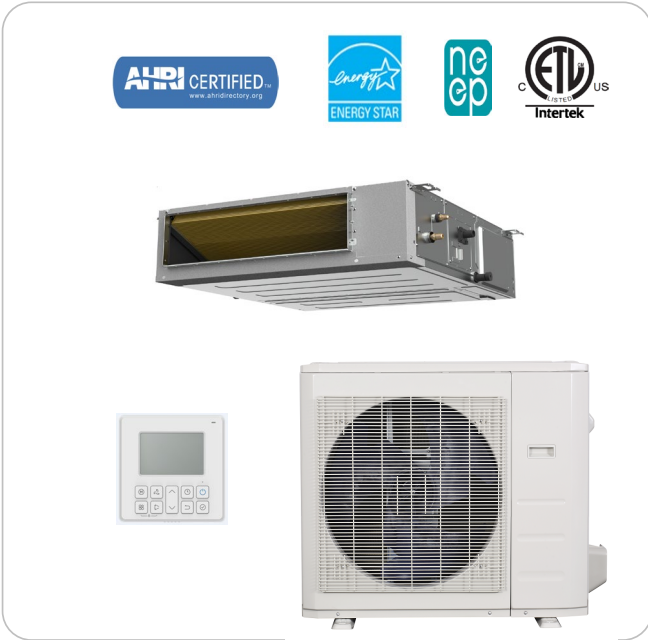

INDOOR SPECIFICATION

Indoor Air Flow (Turbo/H/M/L/Si) (CFM)	853.5 / 706.3 / 618.0 / 500.3 / N/A	
Indoor Noise Level (Turbo/H/M/L/Si) (dBA)	43/40.0/38/35.5/29.5	
Indoor static pressure range	0-0.8	
Dimension (W×D×H)	inch	39.37 x 29.53 x 9.65
Package (W×D×H)	inch	48.23 x 33.86 x 11.97
Net/Gross Weight	lbs	80.47/91.93

OUTDOOR SPECIFICATION

Compressor Type	ROTARY	
Compressor Model	KTM240D46UKT2	
Refrigerant	R454B	
Refrigerant Oil Charge(mL)	620	
Refrigerant Oil	4.15/9.30	
Outdoor Air Flow (Max) (CFM)	2236.7	
Outdoor Noise Level (dBA)	60.0	
Dimension (W×D×H)	inch	37.24 x 16.14 x 31.89
Package (W×D×H)	inch	42.91 x 19.68 x 34.84
Net/Gross Weight	lbs	122.13/132.28

EFFICIENCY

Cooling		Heating	
SEER2	19.0	HSPF2-4	11.0
EER2	12.5	COP	3.64

PERFORMANCE of Cooling

Cooling (Btu/hr)	
Rated Capacity	24000
Min/Max Capacity	8500~28300
Moisture Removal(L/h)	2.14
Standard Operating Range(°F/°C)	-13~122(-25~50)
Conditions:	Indoor: 80°F DB/67°F WB Outdoor: 95°F DB/75°F WB

PERFORMANCE of Heating

Heating (Btu/hr)	
1. @ 47°F Rated	25000
1. @ 47°F Min/Max Capacity	11800~35100
2. @ 17°F Rated	21200
3. @ 5°F Rated: Capacity / COP	19000/2.30
3. @ 5°F Max: Capacity	19000
Standard Operating Range(°F/°C)	-13~75(-25~24)
1. Conditions:	Indoor: 70°F DB/60°F WB Outdoor: 47°F DB/43°F WB
2. Conditions:	Indoor: 70°F DB/60°F WB Outdoor: 17°F DB/15°F WB
3. Conditions:	Indoor: 70°F DB/60°F WB Outdoor: 5°F DB/5°F WB

ELECTRICAL

Power Supply	208/230V,60Hz,1Ph
System MCA	24.00
Connection Wiring	14#x4
System MOCP	25
Compressor RLA	15.4
Outdoor Fan Motor RLA	1.0
Outdoor Fan Motor W	120
Indoor Fan Motor RLA	2.2
Indoor Fan Motor W	165
System Power Input @ Cooling (W)	1920(960 ~ 2710)
System Power Input @ Heating (W)	2010(725 ~3000)
MCA: Min. circuit amps (A)	MOCP: Max. over current protection (A)
RLA: Rated load amps (A)	W: Fan motor rated output (W)

PIPING

Throttle type(Indoor)	N/A
Throttle type(Outdoor)	EXV+Throttle valve
Liquid Size	9.52mm(3/8in)
Gas Size	15.9mm(5/8in)
Max. Piping Length(ft/m)	164.00(50)
Max. Height Difference(ft/m)	82.00(25)
Max. Pre-charged Length(ft/m)	24.6(7.5)
Refrigerant Pre-charged Amount(oz/kg)	70.55(2.00)
Additional Charge of Refrigerant((oz/ft)/(g/m))	0.32(30)
Connection Method	Flared

Features

- Compatible with both horizontal and vertical installation
- Static pressure up to 0.8 in.w.g(for all models)
- Static pressure setting stages: 8
- Refrigerant leakage detection sensor
- Constant airflow
- Built-in pump
- i-clean
- Fan speed stages: 1~100%
- WiFi capability: through wired controller with built-in WiFi
- OTA(by using wired controller 120N(X6W))
- 2-pin connector(HA/HB) for programmable wired controller
- Multiple control options available:
 - Two way communication wired controller:120N(X6)
 - Two way communication wired controller with built-in WiFi:120N(X6W)
 - Infrared wired controller: 120L
 - Wireless remote controller
 - Third-Party 24V Thermostat*

Installation Instruction

Installation place

The distance between the mounted indoor unit should meet the specifications illustrated in the following diagram.

1) Ceiling-mounted

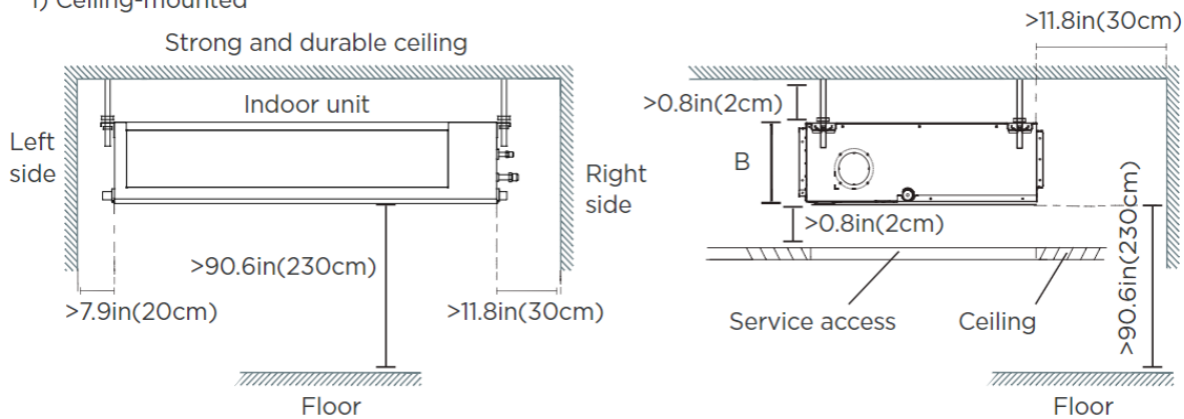

2) Wall-mounted

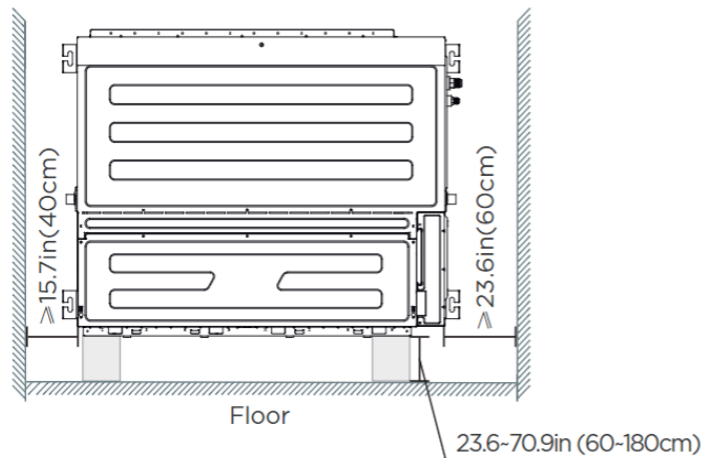

Outdoor Unit Dimension

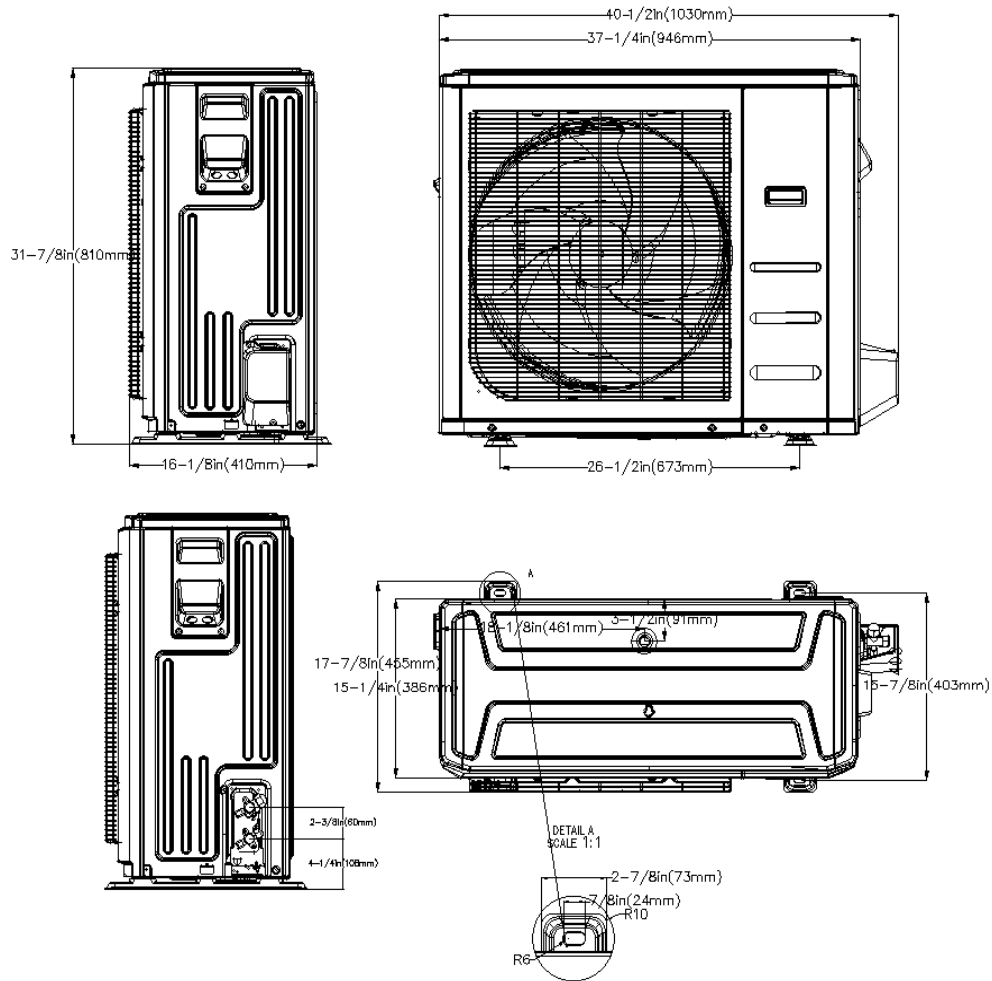

Installation Instruction

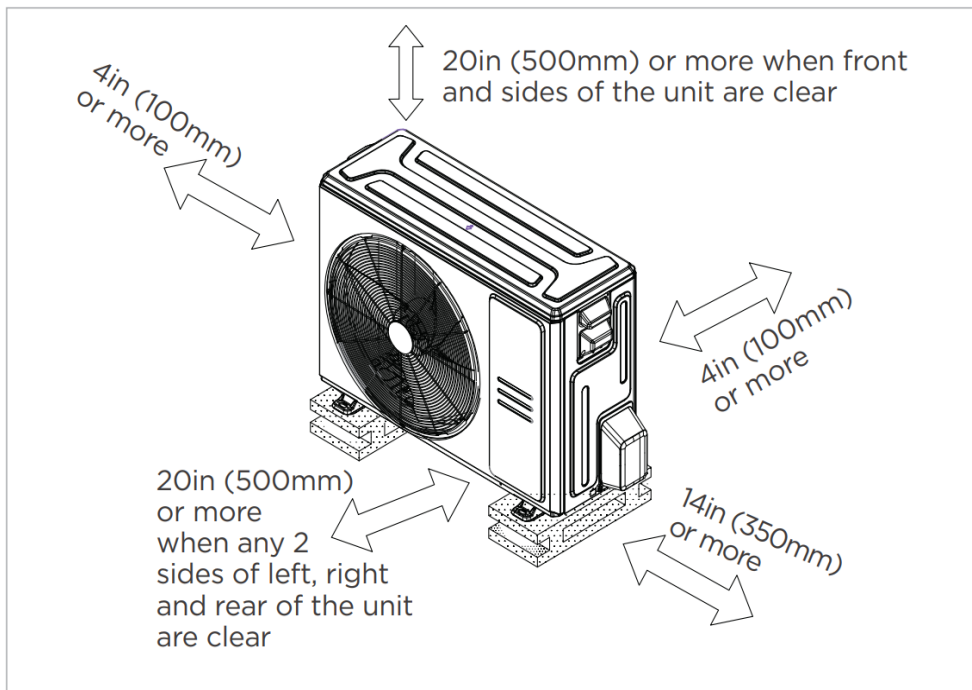

✓ Meets all spatial requirements shown in Installation Clearance Requirements above.

Fan performance

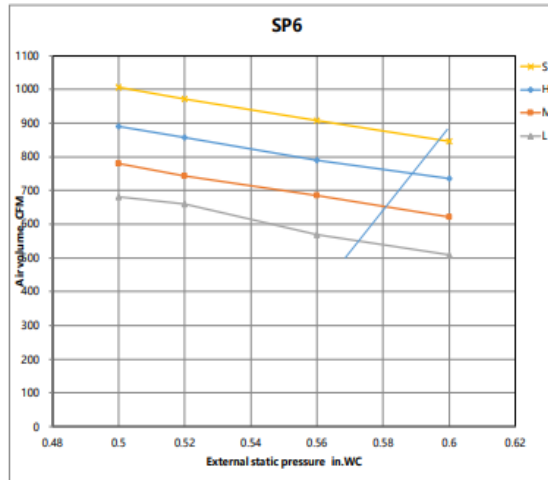
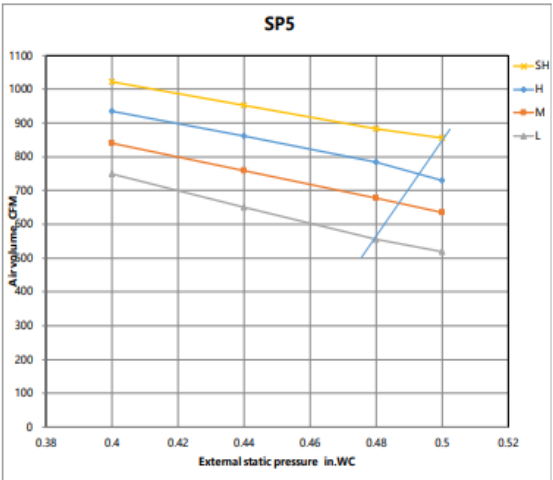
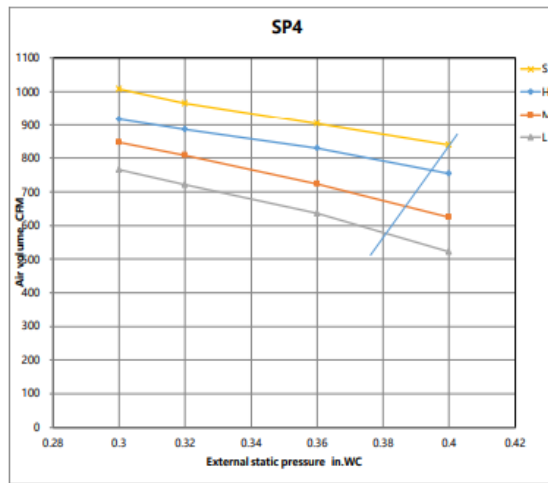
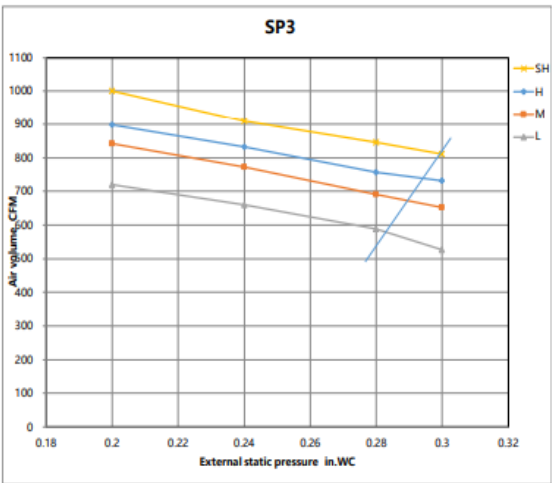
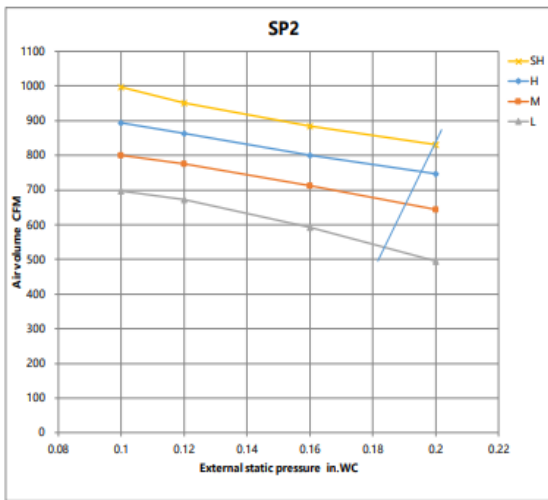
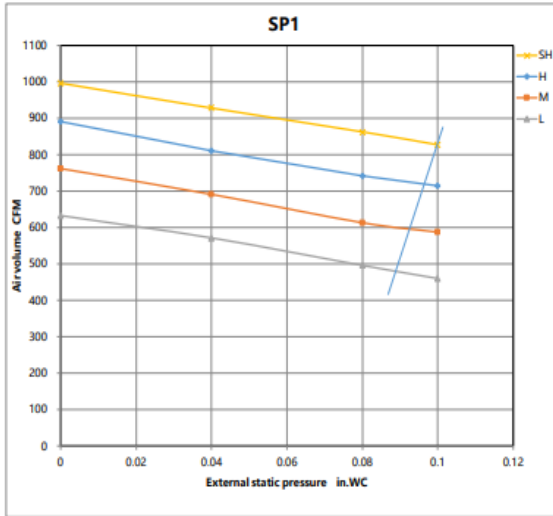

Fan performance

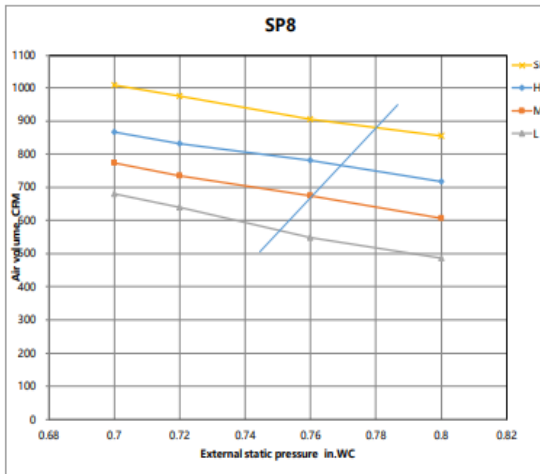
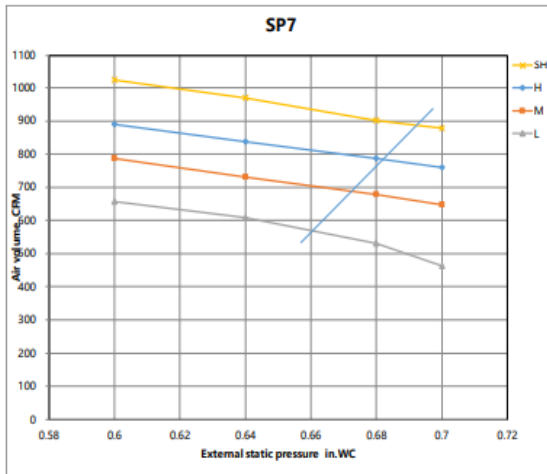

Constant air volume

