



21 SERIES

Submittal Data
9H421YIMI/ 9H421YOMI

9,000 BTU - Single Zone Wall Mount Heat Pump System

Job Name:	Location:
Purchaser:	P.O. Number:
Engineer:	Architect:
Submitted to:	Date:
Submitted By:	For: <input type="checkbox"/> Reference <input type="checkbox"/> Approval <input type="checkbox"/> Construction



Standard Features:

- WiFi Compatible With Accessory
- SeaBreeze+ App Control
- 1 year parts/ 5 year compressor warranty
- R410A Refrigerant
- Auto Restart/ Reset
- Modes: Auto, Cool, Fan, Heat
- Illuminated display On/Off
- Washable Filter
- AHRI Rated
- UL Rated – US and Canada



System Specifications:

Rated BTU	9,000
Voltage / Frequency / Phase	115 / 60 / 1
Minimum Circuit Ampacity	20 Amps
Rated Current	7.82 Amps
Max Fuse	30 Amps
BTU/h (Cooling)	9,000
BTU/h (Heating @47°)	10,000
SEER	21.5
EER	12.5
Application Area (Sq Ft)	129.17~193.75
Indoor Temperature (Cooling/Heating)	60~86/32~86
Outdoor Design Temperature (Cooling/Heating)	5~122 / 5~75
Maximum Vertical Height	33 ft.
Maximum Distance (indoor to outdoor)	82 ft.

INDOOR UNIT

Dimensions (approx.) W / D / H	28.70x7.87x11.50
Sound Power Level Db(A), H / M / L	38/28/20
Air Circulation (CFM), H / M / L	239/170/137
Net/Gross weight	17.64/22.71

OUTDOOR UNIT

Dimensions (approx.) W / D / H	30.12x11.93x21.85
Sound Power Level Db(A)	55
Net/Gross weight	57.76/63.49
Liquid Line (O.D.)	1/4"
Suction Line (O.D.)	3/8"
Metering Method	Capillary +EXV
Air Circulation (CFM)	1294.12
Refrigerant Precharge	25 ft
Additional Charge for each ft over 25ft	0.16 oz/ft
Compressor Type	Rotary

Installation Specifications:

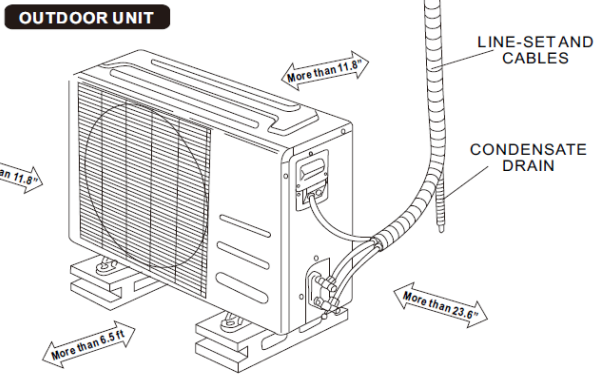
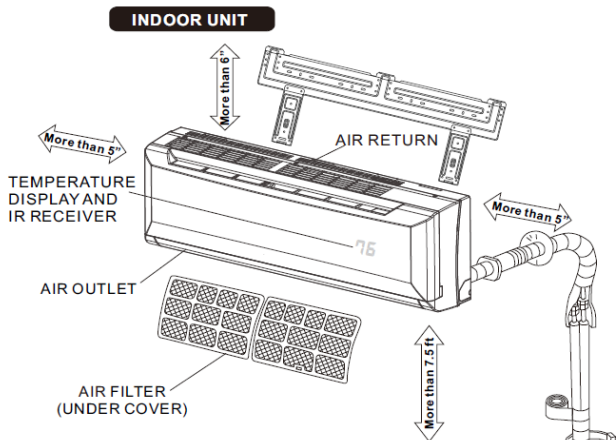

Wall Bracket Installation:

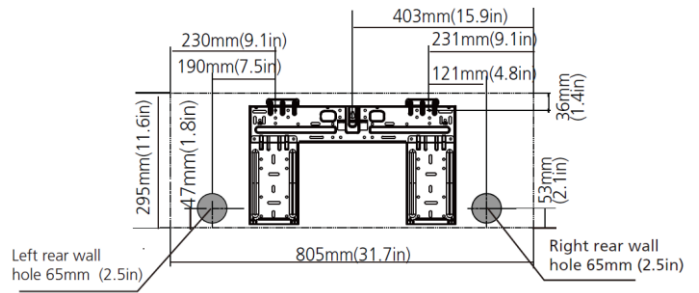

Terminal Wiring

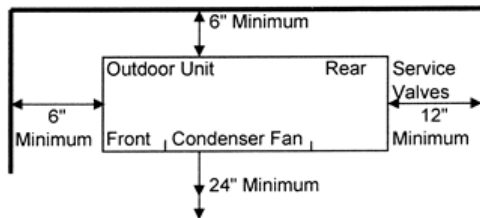
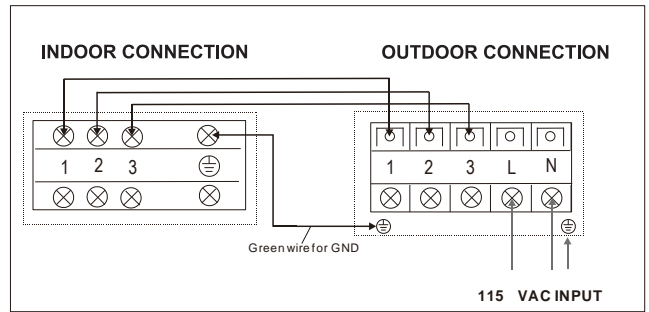

Install the Outdoor unit on a Condenser Pad or if a Heat Pump use feet to raise unit up approx 6" to allow for defrost to drain away

WARRANTY

International Refrigeration Products warrants that the product supplied is free from defects in material and workmanship. This warranty is valid as long as this product is properly handled, installed, operated and serviced in accordance with the Installation and Operating Instructions shipped with this unit, and the warranty card is completed and mailed no later than 30 days after date of purchase. All warranty claims must be made within one (1) years on parts and (5) years on the compressor - from date of purchase (unless national regulations require a longer registration period).

This warranty provides free replacement of defective parts only. **Labor is not covered under this warranty. Replacement as a result of normal wear and tear is not covered under this warranty.**

Additional claims are excluded, unless required by national regulations. International Refrigeration Products Inc. is not responsible for incidental, consequential, direct, or indirect damages, or expenses relating to the use of, or the inability to use the product for any purpose. Other implied warranties are excluded.

This constitutes International Refrigeration Products' warranty obligation and replaces any and all prior warranties for this product.

1035 Wheeler Way
Langhorne, PA 19047
Service - Tel: 215-750-9876 Fax: 215-750-1169
www.irpsales.com