

Submittal Data

CA18H424ZMI



18,000 BTU – Ceiling Cassette Evaporator

Job Name:	Location:
Purchaser:	P.O. Number:
Engineer:	Architect:
Submitted to:	Date:
Submitted By:	For: <input type="checkbox"/> Reference <input type="checkbox"/> Approval <input type="checkbox"/> Construction



Standard Features:

- 2 Year Parts Warranty
- Low-Ambient Cooling
- R410A Refrigerant
- Multi/Single Zone System Configuration
- Heat-Pump System
- AHRI Rated
- UL Rated – US and Canada
- Wifi Optional



Unit Specifications:

Capacities

Rated BTU	18,000
BTU/h (Cooling)	16,000
BTU/h (Heating)	18,500
Cooling Operating Range (Deg. °F)	-13 ~ 122
Heat Operating Range (Deg. °F)	-13 ~ 75
SEER	20.5
EER	12.5
Fan Motor Speed (Hi/Md/Low)	730/630/570
Air Circulation (CFM)	562.4/485.3/438.8
Sound Power Level Db(A)	43.5/38.5/35.5
Indoor Selection Range	60 ~ 90
Application Area (Sq. Ft)	247.57 ~ 355.21
Condensate Pump Lift (ft)	2.5

Electrical

Rated Voltage	208/230, 60, 1
Min. Circuit Ampacity	17
Rated Current (Cooling/Heating)	3.92/4.78
Max. Fuse	25
Connection Wiring	14*4 / 16 *4 AWG

Physical

Dimensions (W/D/H)	22.44x22.44x10.24
Grille/Panel Dimensions W/D/H	25.47x25.47x1.97
Net/ Gross Weight (lbs)	34.83/44.31
Grille/Panel Weight(lbs)	5.52
Liquid Line (O.D.)	1/4"
Suction Line (O.D.)	1/2"
Metering Method	Capillary +EXV

Installation Specifications:

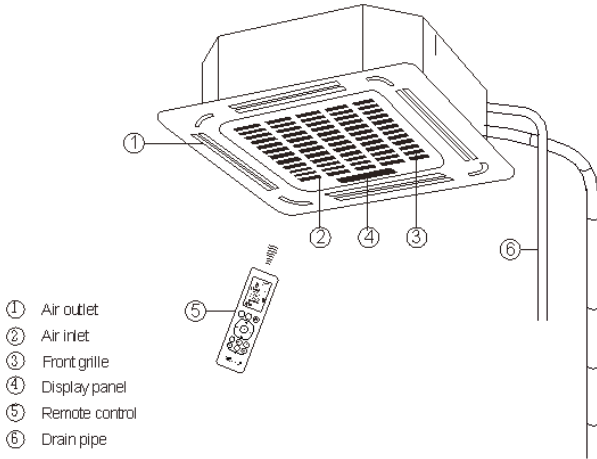

- ① Air outlet
- ② Air inlet
- ③ Front grille
- ④ Display panel
- ⑤ Remote control
- ⑥ Drain pipe

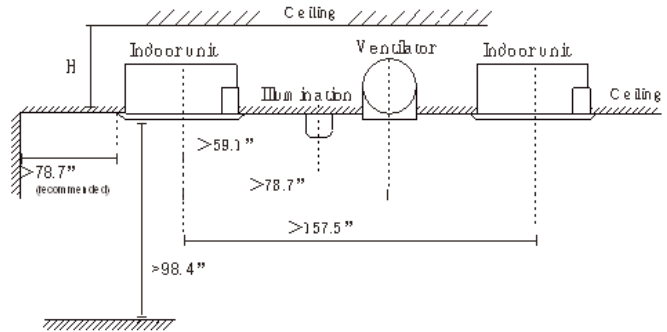
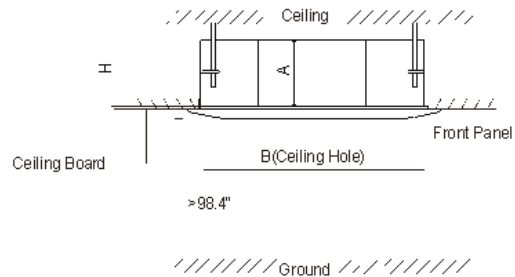
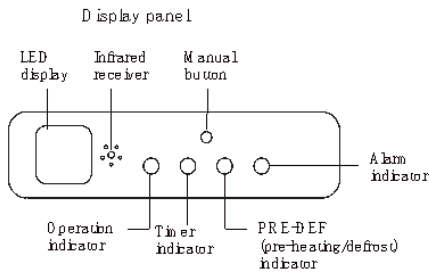

The distance between the mounted indoor unit and the internal ceiling should meet the following specifications.

Model	A	H	B
CA9H424ZMI	10.2"	11.4"	23.6"
CA12H424ZMI			
CA18H424ZMI			

WARRANTY

International Refrigeration Products warrants that the product supplied is free from defects in material and workmanship. This warranty is valid as long as this product is properly handled, installed, operated and serviced in accordance with the Installation and Operating Instructions shipped with this unit, and the warranty card is completed and mailed no later than 30 days after date of purchase. All warranty claims must be made within one (2) years on parts and (7) years on the compressor - from date of purchase (unless national regulations require a longer registration period).

This warranty provides free replacement of defective parts only. **Labor is not covered under this warranty. Replacement as a result of normal wear and tear is not covered under this warranty.**

Additional claims are excluded, unless required by national regulations. International Refrigeration Products Inc. is not responsible for incidental, consequential, direct, or indirect damages, or expenses relating to the use of, or the inability to use the product for any purpose. Other implied warranties are excluded.

This constitutes International Refrigeration Products' warranty obligation and replaces any and all prior warranties for this product.

1035 Wheeler Way
 Langhorne, PA 19047
 Service - Tel: 215-750-9876 Fax: 215-750-1169
 www.irpsales.com