

Submittal Data

MZ18H424ZMO



18,000 BTU – Multi-Zone Heat Pump Condensing Unit

Job Name:	Location:
Purchaser:	P.O. Number:
Engineer:	Architect:
Submitted to:	Date:
Submitted By:	For: <input type="checkbox"/> Reference <input type="checkbox"/> Approval <input type="checkbox"/> Construction



Standard Features:

- 7 Year Compressor Warranty
- 2 Year Parts Warranty
- Inverter Compressor Technology
- Low-Ambient Cooling
- R410A Refrigerant
- Dual Zone System
- Heat-Pump System
- AHRI Rated
- UL Rated – US and Canada



System Specifications:

Rated BTU	18,000
Voltage / Frequency / Phase	208/230 / 60 / 1
Minimum Circuit Ampacity	18 Amps
Rated Current	6.2 Amps
Max Fuse	25 Amps
BTU/h (Cooling)	18,000
BTU/h (Heating @47°)	19,000
Outdoor Temp. Range (Cooling / Heating)	-13~122 / -13~86
Max. Vertical Height	49 ft.
Max. Distance (Total)	131 ft.
Max. Distance (For One Indoor Unit)	82 ft.
Max. Height Difference between indoor units	33 ft.
Refrigerant Precharge	49 ft.
Additional Charge For Each Foot Over (49 ft.)	0.161 oz/ft
Design Pressure High/Low	550 / 340 PSIG
Refrigerant Oil/ Oil Charge	VG74/450 ml
Refrigerant Type	R410A

OUTDOOR UNIT

Dimensions (approx.) W / D / H	35.04 x 13.46 x 26.50
Sound Power Level Db(A)	58.50
Net/Gross Weight	100.31 / 108.69 Lbs
Liquid Line (O.D.)	(2x) 1/4"
Suction Line (O.D.)	(2x) 3/8"
Metering Method	Capillary +EXV
Air Circulation (CFM)	1764.71
Compressor Type	Rotary
SEER	22.5
EER	13.3

Installation Specifications:

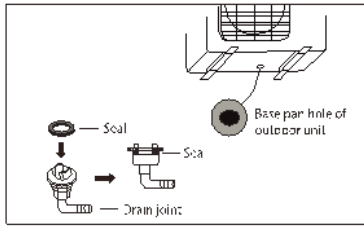

Figure 18a

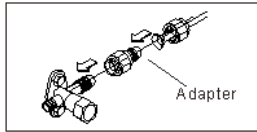

Figure 18b

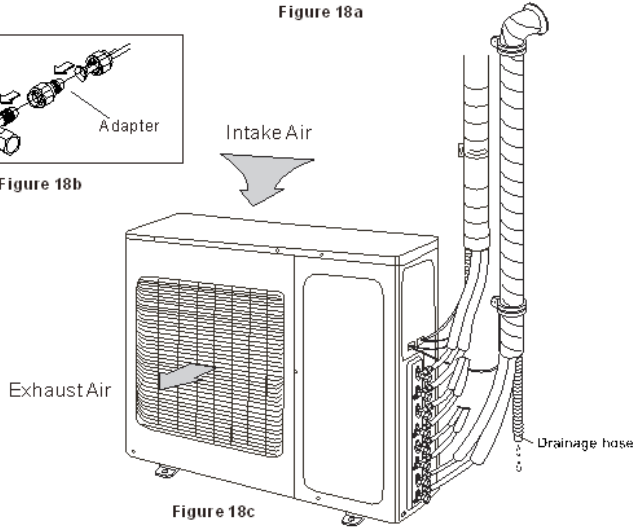
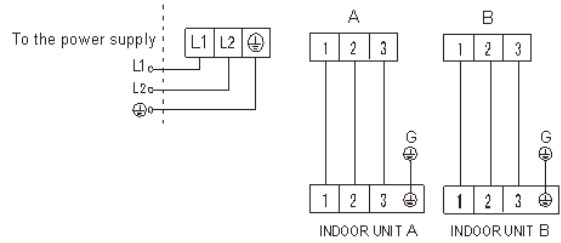

Figure 18c

Terminal Wiring



Connection Length	MZ18H424ZMO DUAL ZONE
Total Length	$L1+L2 \leq 131$ ft.
Max. Length for any indoor unit	82 ft.
Max. Height between each indoor and the outdoor unit	49.2 ft.
Max. Height difference between indoor units	32.8 ft.

Outdoor Unit Location

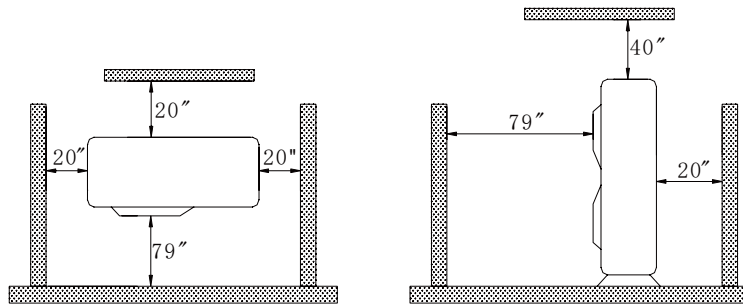

WARRANTY

International Refrigeration Products warrants that the product supplied is free from defects in material and workmanship. This warranty is valid as long as this product is properly handled, installed, operated and serviced in accordance with the Installation and Operating Instructions shipped with this unit, and the warranty card is completed and mailed no later than 30 days after date of purchase. All warranty claims must be made within one (2) years on parts and (7) years on the compressor - from date of purchase (unless national regulations require a longer registration period).

This warranty provides free replacement of defective parts only. **Labor is not covered under this warranty. Replacement as a result of normal wear and tear is not covered under this warranty.**

Additional claims are excluded, unless required by national regulations. International Refrigeration Products Inc. is not responsible for incidental, consequential, direct, or indirect damages, or expenses relating to the use of, or the inability to use the product for any purpose. Other implied warranties are excluded.

This constitutes International Refrigeration Products' warranty obligation and replaces any and all prior warranties for this product.

1035 Wheeler Way
Langhorne, PA 19047
Service - Tel: 215-750-9876 Fax: 215-750-1169
www.irpsales.com