

# Submittal Data

## MZ48H424ZMO



### 48,000 BTU – Multi-Zone Heat Pump Condensing Unit

Job Name:	Location:
Purchaser:	P.O. Number:
Engineer:	Architect:
Submitted to:	Date:
Submitted By:	For: <input type="checkbox"/> Reference <input type="checkbox"/> Approval <input type="checkbox"/> Construction



#### Standard Features:

- 7 Year Compressor Warranty
- 2 Year Parts Warranty
- Inverter Compressor Technology
- Low-Ambient Cooling
- R410A Refrigerant
- Dual Zone System
- Heat-Pump System
- AHRI Rated
- UL Rated – US and Canada



#### System Specifications:

Rated BTU	48,000
Voltage / Frequency / Phase	208/230 / 60/1
Minimum Circuit Ampacity	40 Amps
Rated Current	16.8 Amps
Max Fuse	60 Amps
BTU/h (Cooling)	48,000
BTU/h (Heating @47°)	48,000
Outdoor Temp. Range (Cooling / Heating)	-13~122 / -13~86
Max. Vertical Height	49 ft.
Max. Distance (Total)	262 ft.
Max. Distance (For One Indoor Unit)	115 ft..
Max. Height Difference between indoor units	33 ft.
Refrigerant Precharge	123 ft.
Additional Charge For Each Foot Over (123 ft.) 1/4"/ 3/8"	0.161 / 0.322 oz/ft
Design Pressure High/Low	550 / 340
Refrigerant Oil/ Oil Charge	VG74/1400 ml
Refrigerant Type	R410A

#### OUTDOOR UNIT

Dimensions (approx.) W / D / H	37.48 x 16.34 x 52.48
Sound Power Level Db(A)	64
Net/Gross Weight	225.53 / 256.62 Lbs
Liquid Line (O.D.)	(5x) 1/4"
Suction Line (O.D.)	(3x) 3/8" (2x) 1/2"
Metering Method	Capillary +EXV
Air Circulation (CFM)	4500.06
Compressor Type	Rotary
SEER	22.4
EER	12.5

# Installation Specifications:

## Terminal Wiring

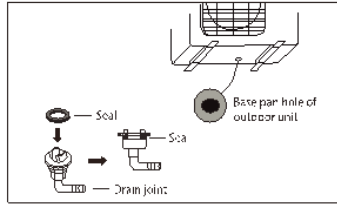

Figure 18a

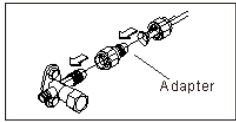

Figure 18b

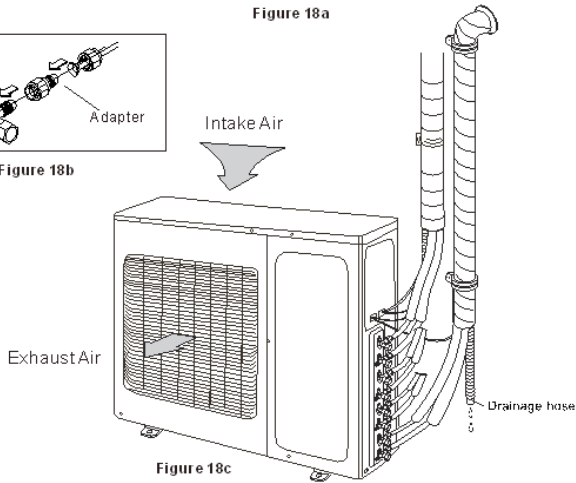
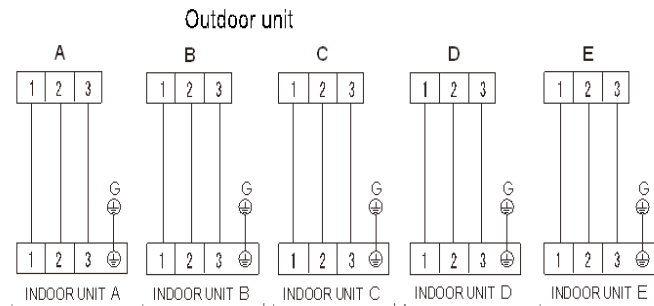
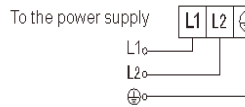
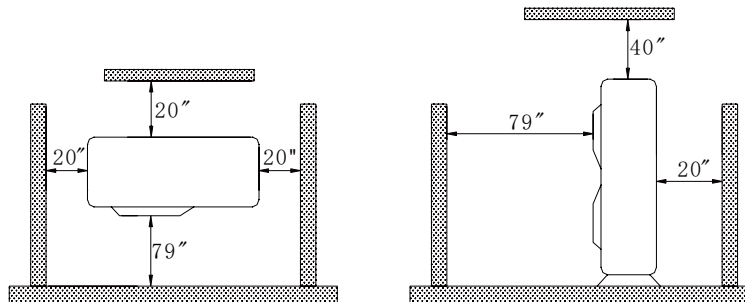

Figure 18c



Connection Length	MZ48H424ZMO
Total Length	$L1+L2+L3+L4+L5 \leq 262$ ft.
Lx - Max. Length for any indoor unit	115 ft.
H1 - Max. Height between each indoor and the outdoor unit	49.2 ft.
H2 - Max. Height difference between indoor units	32.8 ft.

## Outdoor Unit Location



## WARRANTY

International Refrigeration Products warrants that the product supplied is free from defects in material and workmanship. This warranty is valid as long as this product is properly handled, installed, operated and serviced in accordance with the Installation and Operating Instructions shipped with this unit, and the warranty card is completed and mailed no later than 30 days after date of purchase. All warranty claims must be made within one (2) years on parts and (7) years on the compressor - from date of purchase (unless national regulations require a longer registration period).

This warranty provides free replacement of defective parts only. **Labor is not covered under this warranty. Replacement as a result of normal wear and tear is not covered under this warranty.**

Additional claims are excluded, unless required by national regulations. International Refrigeration Products Inc. is not responsible for incidental, consequential, direct, or indirect damages, or expenses relating to the use of, or the inability to use the product for any purpose. Other implied warranties are excluded.

This constitutes International Refrigeration Products' warranty obligation and replaces any and all prior warranties for this product.

1035 Wheeler Way  
Langhorne, PA 19047  
Service - Tel: 215-750-9876 Fax: 215-750-1169  
www.irpsales.com