

Submittal Data

CA18H424ZMI / HSZ18H424ZMO



18,000 BTU - Single Zone Peak Heat Ceiling Cassette Heat Pump System

Job Name:	Location:
Purchaser:	P.O. Number:
Engineer:	Architect:
Submitted to:	Date:
Submitted By:	For: <input type="checkbox"/> Reference <input type="checkbox"/> Approval <input type="checkbox"/> Construction



Standard Features:

- WiFi Optional
- SeaBreeze+ App Control
- 2 year parts/ 7 year compressor warranty
- Approx. 100% Heating Capacity @ 5°
- Drain Pan Heater Standard
- R410A Refrigerant
- Auto Restart/ Reset
- Modes: Auto, Cool, Fan, Heat
- Illuminated display On/Off
- Washable Filter
- AHRI Rated
- UL Rated – US and Canada



System Specifications:

Rated BTU	18,000
Voltage / Frequency / Phase	208/230 / 60 / 1
Minimum Circuit Ampacity	16 Amps
Rated Current	11 Amps
Max Fuse	25 Amps
BTU/h (Cooling)	16,000
BTU/h (Heating @5°)	16,000
SEER	20
EER	12.5
Application Area (Sq Ft)	226.04~333.68
Indoor Temperature (Cooling/Heating)	60~90 / 32~86
Outdoor Design Temperature (Cooling/Heating)	-22~-122 / -22~-75
Maximum Vertical Height	66 ft.
Maximum Distance (indoor to outdoor)	98 ft.
Condensate Pump Lift (ft)	2.5

INDOOR UNIT

Dimensions (approx.) W / D / H	22.44x22.44x10.24
Grille/Panel Dimensions W/D/H	25.47x25.47x1.97
Sound Power Level Db(A), H / M / L	43.5/38.5/35.5
Air Circulation (CFM), H / M / L	562.35/485.29/438.82
Net/Gross weight (lbs)	35.71/46.96
Grille/Panel Weight(lbs)	5.52/9.92

OUTDOOR UNIT

Dimensions (approx.) W / D / H	35.04x13.46x26.50
Sound Power Level Db(A)	59
Net/Gross weight (lbs)	100.97/108.03
Liquid Line (O.D.)	1/4"
Suction Line (O.D.)	1/2"
Metering Method	Capillary +EXV
Air Circulation (CFM)	1764.70
Refrigerant Precharge	25 ft
Additional Charge for each ft over 25ft	0.161 oz/ft
Compressor Type	Rotary

Installation Specifications:

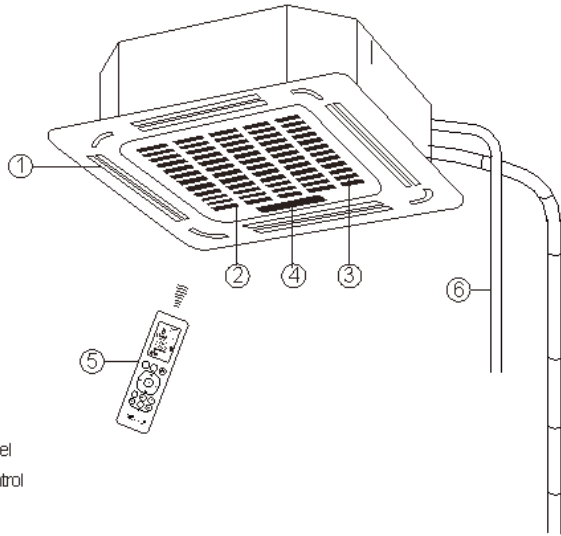

- ① Air outlet
- ② Air inlet
- ③ Front grille
- ④ Display panel
- ⑤ Remote control
- ⑥ Drain pipe

Display panel

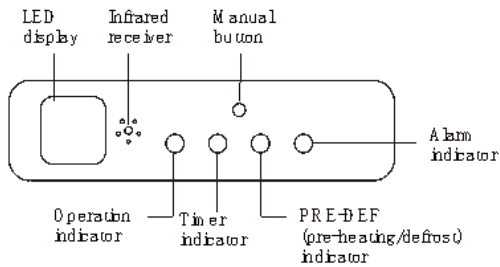

Wiring Diagram

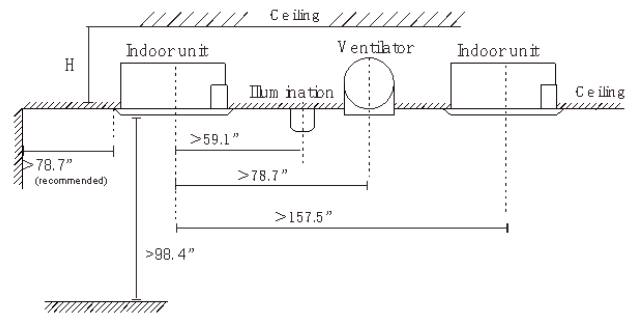
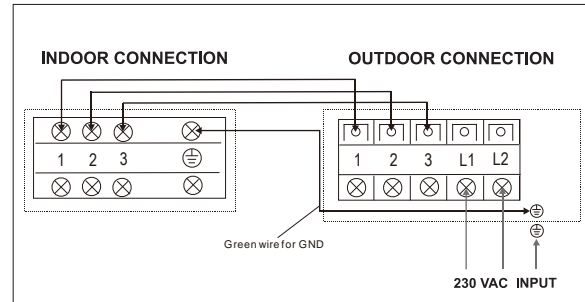

The distance between the mounted indoor unit and the internal ceiling should meet the following specifications.

Model	A	H	B
CA9H424ZMI	10.2"	11.4"	23.6"
CA12H424ZMI			
CA18H424ZMI			

WARRANTY

International Refrigeration Products warrants that the product supplied is free from defects in material and workmanship. This warranty is valid as long as this product is properly handled, installed, operated and serviced in accordance with the Installation and Operating Instructions shipped with this unit, and the warranty card is completed and mailed no later than 30 days after date of purchase. All warranty claims must be made within one (2) years on parts and (7) years on the compressor - from date of purchase (unless national regulations require a longer registration period).

This warranty provides free replacement of defective parts only. **Labor is not covered under this warranty. Replacement as a result of normal wear and tear is not covered under this warranty.**

Additional claims are excluded, unless required by national regulations. International Refrigeration Products Inc. is not responsible for incidental, consequential, direct, or indirect damages, or expenses relating to the use of, or the inability to use the product for any purpose. Other implied warranties are excluded.

This constitutes International Refrigeration Products' warranty obligation and replaces any and all prior warranties for this product.

1035 Wheeler Way
 Langhorne, PA 19047
 Service - Tel: 215-750-9876 Fax: 215-750-1169
 www.irpsales.com