

# Submittal Data

## CA24H424ZMI / HSZ24H424ZMO



### 24,000 BTU - Single Zone Peak Heat Ceiling Cassette Heat Pump System

|               |   |
|---------------|---|
| Job Name:     | Location:   |
| Purchaser:    | P.O. Number:  |
| Engineer:     | Architect:  |
| Submitted to: | Date:   |
| Submitted By: | For: <input type="checkbox"/> Reference <input type="checkbox"/> Approval <input type="checkbox"/> Construction |

#### Standard Features:

- WiFi Optional
- SeaBreeze+ App Control
- 2 year parts/ 7 year compressor warranty
- Approx. 100% Heating Capacity @ 5°
- Drain Pan Heater Standard
- R410A Refrigerant
- Auto Restart/ Reset
- Modes: Auto, Cool, Fan, Heat
- Illuminated display On/Off
- Washable Filter
- AHRI Rated
- UL Rated – US and Canada



#### System Specifications:

|  |                    |
|--|--------------------|
| Rated BTU                                    | 24,000             |
| Voltage / Frequency / Phase                  | 208/230 / 60 / 1   |
| Minimum Circuit Ampacity                     | 25 Amps            |
| Rated Current                                | 9.8 Amps           |
| Max Fuse                                     | 35 Amps            |
| BTU/h (Cooling)                              | 24,000             |
| BTU/h (Heating @5°)                          | 24,100             |
| SEER   | 20.2               |
| EER  | 11                 |
| Application Area (Sq Ft)                     | 344.44~505.90      |
| Indoor Temperature (Cooling/Heating)         | 60~90 / 32~86      |
| Outdoor Design Temperature (Cooling/Heating) | -22~-122 / -22~-75 |
| Maximum Vertical Height                      | 82 ft.             |
| Maximum Distance (indoor to outdoor)         | 164 ft.            |
| Condensate Pump Lift (ft)                    | 3.28               |

#### INDOOR UNIT

|                                    |                      |
|------------------------------------|----------------------|
| Dimensions (approx.) W / D / H     | 32.68x32.68x8.07     |
| Grille/Panel Dimensions W/D/H      | 37.40x37.40x2.17     |
| Sound Power Level Db(A), H / M / L | 48/45.5/43           |
| Air Circulation (CFM), H / M / L   | 705.88/635.29/547.06 |
| Net/Gross weight (lbs)             | 47.18/55.34          |
| Grille/Panel Weight(lbs)           | 13.23/19.84          |

#### OUTDOOR UNIT

|   |                   |
|---|-------------------|
| Dimensions (approx.) W / D / H          | 37.24x16.14x31.89 |
| Sound Power Level Db(A)                 | 62                |
| Net/Gross weight (lbs)                  | 134.48/144.40     |
| Liquid Line (O.D.)                      | 3/8"              |
| Suction Line (O.D.)                     | 5/8"              |
| Metering Method                         | Capillary +EXV    |
| Air Circulation (CFM)                   | 2235.30           |
| Refrigerant Precharge                   | 25 ft             |
| Additional Charge for each ft over 25ft | 0.32 oz/ft        |
| Compressor Type                         | Rotary            |

# Installation Specifications:

## Wiring Diagram

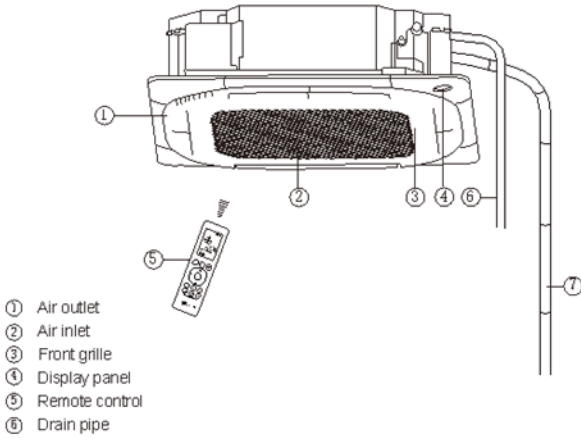

- ① Air outlet
- ② Air inlet
- ③ Front grille
- ④ Display panel
- ⑤ Remote control
- ⑥ Drain pipe

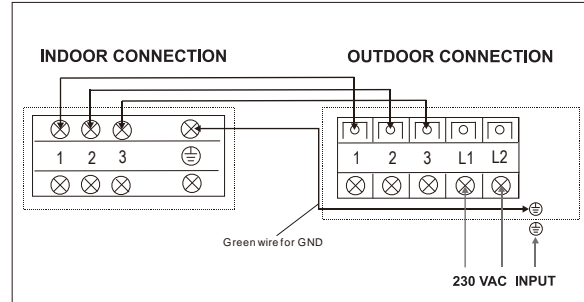

### Display Panel

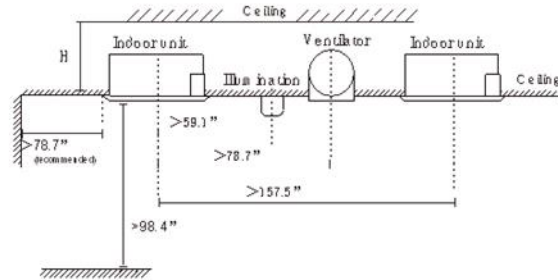
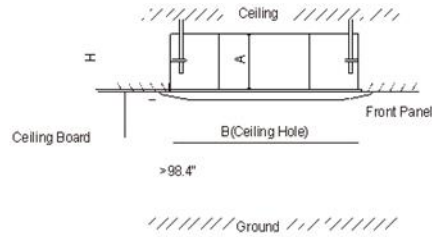
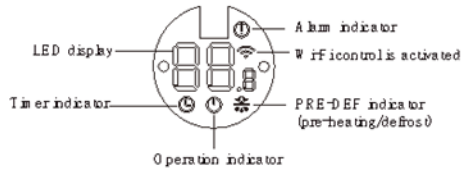

The distance between the mounted indoor unit and the internal ceiling should meet the following specifications.

| Model       | A    | H    | B     |
|-------------|------|------|-------|
| CA24H424ZMI | 8.0" | 9.3" | 34.5" |

## WARRANTY

International Refrigeration Products warrants that the product supplied is free from defects in material and workmanship. This warranty is valid as long as this product is properly handled, installed, operated and serviced in accordance with the Installation and Operating Instructions shipped with this unit, and the warranty card is completed and mailed no later than 30 days after date of purchase. All warranty claims must be made within one (2) years on parts and (7) years on the compressor - from date of purchase (unless national regulations require a longer registration period).

This warranty provides free replacement of defective parts only. **Labor is not covered under this warranty. Replacement as a result of normal wear and tear is not covered under this warranty.**

Additional claims are excluded, unless required by national regulations. International Refrigeration Products Inc. is not responsible for incidental, consequential, direct, or indirect damages, or expenses relating to the use of, or the inability to use the product for any purpose. Other implied warranties are excluded.

This constitutes International Refrigeration Products' warranty obligation and replaces any and all prior warranties for this product.

1035 Wheeler Way  
 Langhorne, PA 19047  
 Service - Tel: 215-750-9876 Fax: 215-750-1169  
 www.irpsales.com