

Submittal Data

WM18H424ZMI



18,000 BTU – Wall Mounted Evaporator

Job Name:	Location:
Purchaser:	P.O. Number:
Engineer:	Architect:
Submitted to:	Date:
Submitted By:	For: <input type="checkbox"/> Reference <input type="checkbox"/> Approval <input type="checkbox"/> Construction



Standard Features:

- 2 Year Parts Warranty
- Low-Ambient Cooling
- R410A Refrigerant
- Multi/Single Zone System Configuration
- Heat-Pump System
- AHRI Rated
- UL Rated – US and Canada
- Wifi Enabled



Unit Specifications:

<p>Capacities</p> <table style="width: 100%;"> <tr><td>Rated BTU</td><td style="text-align: right;">18,000</td></tr> <tr><td>BTU/h (Cooling)</td><td style="text-align: right;">18,000</td></tr> <tr><td>BTU/h (Heating)</td><td style="text-align: right;">18,000</td></tr> <tr><td>Cooling Operating Range (Deg. °F)</td><td style="text-align: right;">-13 ~ 122</td></tr> <tr><td>Heat Operating Range (Deg. °F)</td><td style="text-align: right;">-13 ~ 75</td></tr> <tr><td>SEER</td><td style="text-align: right;">24</td></tr> <tr><td>EER</td><td style="text-align: right;">13.5</td></tr> <tr><td>Fan Motor Speed (Hi/Md/Low)</td><td style="text-align: right;">1120 / 950 / 700</td></tr> <tr><td>Air Circulation (CFM)</td><td style="text-align: right;">530.59 / 458.82 / 382.35</td></tr> <tr><td>Sound Power Level Db(A)</td><td style="text-align: right;">45.5 / 41 / 24.5</td></tr> <tr><td>Indoor Selection Range</td><td style="text-align: right;">60 ~ 90</td></tr> <tr><td>Application Area (Sq. Ft)</td><td style="text-align: right;">258.33 / 376.74</td></tr> </table>	Rated BTU	18,000	BTU/h (Cooling)	18,000	BTU/h (Heating)	18,000	Cooling Operating Range (Deg. °F)	-13 ~ 122	Heat Operating Range (Deg. °F)	-13 ~ 75	SEER	24	EER	13.5	Fan Motor Speed (Hi/Md/Low)	1120 / 950 / 700	Air Circulation (CFM)	530.59 / 458.82 / 382.35	Sound Power Level Db(A)	45.5 / 41 / 24.5	Indoor Selection Range	60 ~ 90	Application Area (Sq. Ft)	258.33 / 376.74	<p>Electrical</p> <table style="width: 100%;"> <tr><td>Rated Voltage</td><td style="text-align: right;">208/230, 60, 1</td></tr> <tr><td>Min. Circuit Ampacity</td><td style="text-align: right;">17</td></tr> <tr><td>Rated Current (Cooling/Heating)</td><td style="text-align: right;">5.94/6.31</td></tr> <tr><td>Max. Fuse</td><td style="text-align: right;">25</td></tr> <tr><td>Connection Wiring</td><td style="text-align: right;">14*4 / 16 *4 AWG</td></tr> </table> <p>Physical</p> <table style="width: 100%;"> <tr><td>Dimensions (approx.) W/D/H</td><td style="text-align: right;">42.64 x 9.61 x 13.23</td></tr> <tr><td>Package Dimensions W/D/H</td><td style="text-align: right;">45.47 x 16.34 x 12.40</td></tr> <tr><td>Net/ Gross Weight (lbs.)</td><td style="text-align: right;">29.54 / 37.48</td></tr> <tr><td>Liquid Line (O.D.)</td><td style="text-align: right;">1/4"</td></tr> <tr><td>Suction Line (O.D.)</td><td style="text-align: right;">1/2"</td></tr> <tr><td>Metering Method</td><td style="text-align: right;">Capillary +EXV</td></tr> </table>	Rated Voltage	208/230, 60, 1	Min. Circuit Ampacity	17	Rated Current (Cooling/Heating)	5.94/6.31	Max. Fuse	25	Connection Wiring	14*4 / 16 *4 AWG	Dimensions (approx.) W/D/H	42.64 x 9.61 x 13.23	Package Dimensions W/D/H	45.47 x 16.34 x 12.40	Net/ Gross Weight (lbs.)	29.54 / 37.48	Liquid Line (O.D.)	1/4"	Suction Line (O.D.)	1/2"	Metering Method	Capillary +EXV
Rated BTU	18,000																																														
BTU/h (Cooling)	18,000																																														
BTU/h (Heating)	18,000																																														
Cooling Operating Range (Deg. °F)	-13 ~ 122																																														
Heat Operating Range (Deg. °F)	-13 ~ 75																																														
SEER	24																																														
EER	13.5																																														
Fan Motor Speed (Hi/Md/Low)	1120 / 950 / 700																																														
Air Circulation (CFM)	530.59 / 458.82 / 382.35																																														
Sound Power Level Db(A)	45.5 / 41 / 24.5																																														
Indoor Selection Range	60 ~ 90																																														
Application Area (Sq. Ft)	258.33 / 376.74																																														
Rated Voltage	208/230, 60, 1																																														
Min. Circuit Ampacity	17																																														
Rated Current (Cooling/Heating)	5.94/6.31																																														
Max. Fuse	25																																														
Connection Wiring	14*4 / 16 *4 AWG																																														
Dimensions (approx.) W/D/H	42.64 x 9.61 x 13.23																																														
Package Dimensions W/D/H	45.47 x 16.34 x 12.40																																														
Net/ Gross Weight (lbs.)	29.54 / 37.48																																														
Liquid Line (O.D.)	1/4"																																														
Suction Line (O.D.)	1/2"																																														
Metering Method	Capillary +EXV																																														

Installation Specifications:

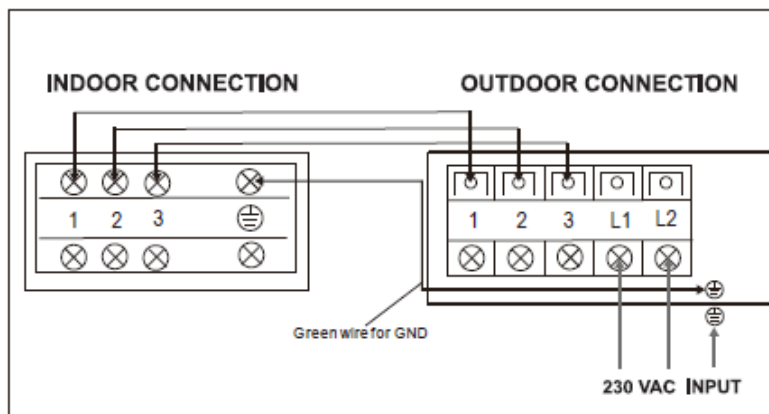
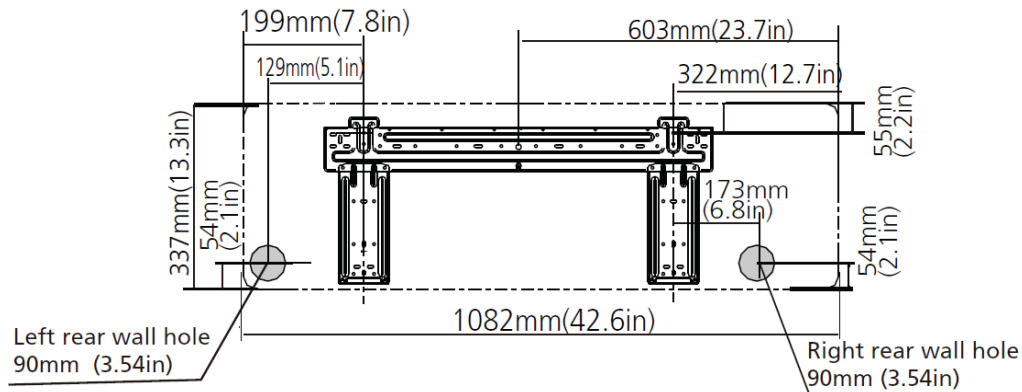
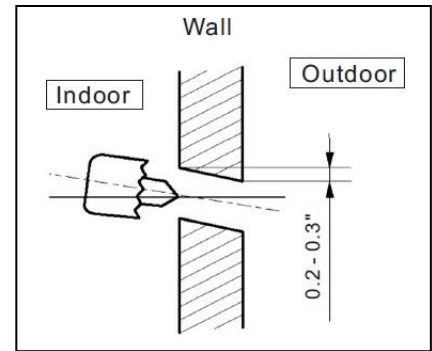
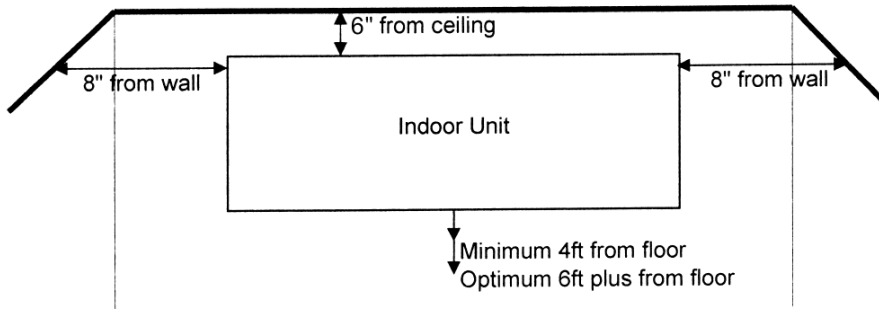

WARRANTY

International Refrigeration Products warrants that the product supplied is free from defects in material and workmanship. This warranty is valid as long as this product is properly handled, installed, operated and serviced in accordance with the Installation and Operating Instructions shipped with this unit, and the warranty card is completed and mailed no later than 30 days after date of purchase. All warranty claims must be made within one (2) years on parts and (7) years on the compressor - from date of purchase (unless national regulations require a longer registration period).

This warranty provides free replacement of defective parts only. **Labor is not covered under this warranty. Replacement as a result of normal wear and tear is not covered under this warranty.**

Additional claims are excluded, unless required by national regulations. International Refrigeration Products Inc. is not responsible for incidental, consequential, direct, or indirect damages, or expenses relating to the use of, or the inability to use the product for any purpose. Other implied warranties are excluded.

This constitutes International Refrigeration Products' warranty obligation and replaces any and all prior warranties for this product.

1035 Wheeler Way
Langhorne, PA 19047
Service - Tel: 215-750-9876 Fax: 215-750-1169
www.irpsales.com